



Why?

Water, dirt and sediments can accumulate in stored diesel fuel and threaten the quality of the fuel and the performance of the engine that will use it. Semler's PetroPolisher™ systems are engineered to remove these threats quickly and efficiently. Our PetroPolisher™ FlexMax 35 is ideal for backup generators, diesel fire suppression pumps, and tanks 1,000-10,000 gallons. Units can be permanently installed or cart-mounted for portability.



Semler Industries Inc.

3800 North Carnation Street
Franklin Park, IL 60131 USA

Phone: (847) 671-5650

Fax: (847) 671-7686

semler@semlerindustries.com

FuelPolishingSolutions.com
SemlerIndustries.com

PetroPolisher™ FlexMax 35



Offers the ultimate in flexibility with operator-selected 1, 2, or 3 stage filtration.

**Maximum Flexibility
Maximum Purity
Maximum Durability**

By incorporating a bag-filter housing, a large element housing and a specific coalescer-separator housing in series, we have allowed for the operator to mix and match a wide variety of media types to address any and almost all concerns with diesel contamination. Not sure which media to use? Don't worry, contact a Semler fuel expert for some guidance and suggestions.

STANDARD PACKAGE

- Easy turn-key operation
- 35gpm self-priming pump
- Electric motor (TEFC), (120v, 20A circuit needed)
- Clear hose for visual confirmation of fuel clarity
- NEMA 4 enclosed control panel with on-off, auto-shutdown and indicator light
- Robust, compact 4-wheel cart with drip pan
- Variable-speed flow control
- Maximum Flexibility Filters:
 - Large, debris-removal bag
 - Water coalescing/separating
 - Water-absorbing elements
 - Surfactant polishing
- Step-down series, soild removal to 5u
- Isolation valves for desired flow paths and filter isolation



OPTIONS

- Flow rates 23 to 200+ gpm
- Compressed air, diesel engine driven or other power options
- Instrumentation and automation
- Coarse or fine filter efficiency
- Explosion proof motor with NEMA 7 control panel
- Color choice
- Permanent installation with timed cycles
- User interface with real-time operating parameters and alarm condition outputs



Solids Removal

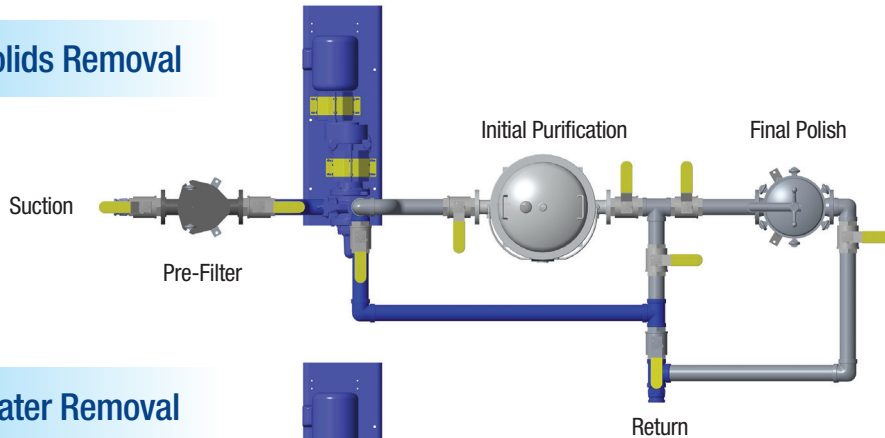

Water Removal

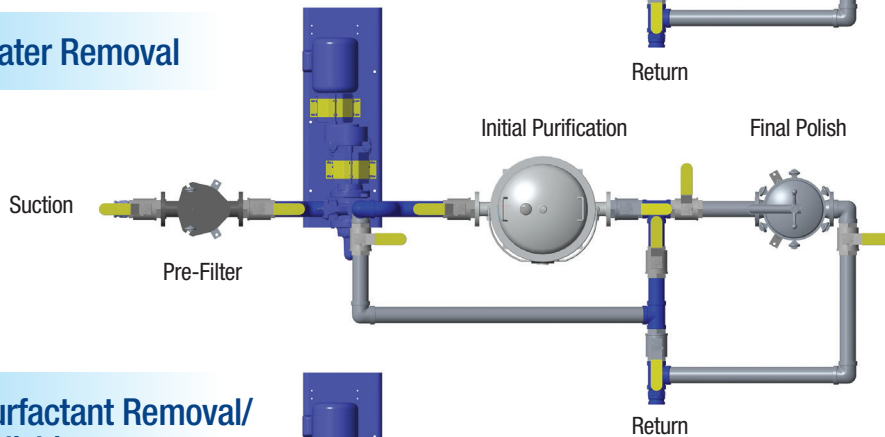

Surfactant Removal/ Polishing

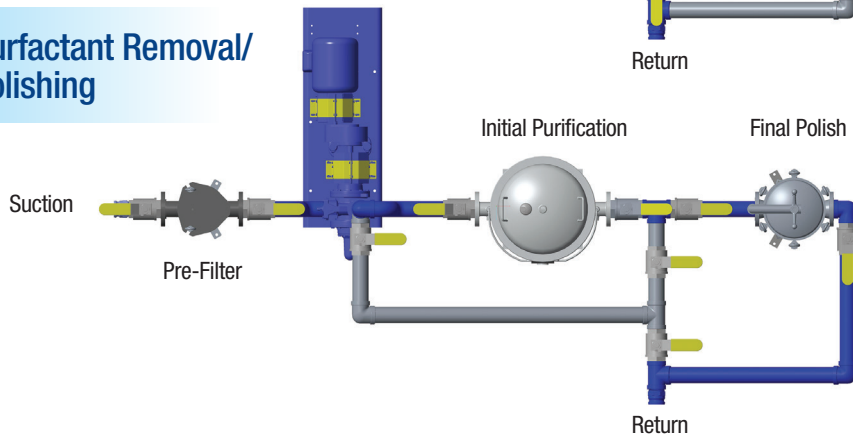

By incorporating a bag-filter housing, a large element housing and a specific coalescer-separator housing in series, we have allowed for the operator to mix and match a wide variety of media types to address any and almost all concerns with diesel contamination. Not sure which media to use? Don't worry- contact a Semler fuel expert for some guidance and suggestions.

OTHER OFFERINGS BY SEMLER



23gpm Single filter
PetroPolishers



35gpm Single filter
PetroPolishers



DEF Transfer Carts
and Systems



200gpm Oil and Engine
Fluid Transfer Skids



Absorbent Media
& Spill Kits

Do you have a unique situation? Many of our customers do. Just let us know and our engineers can custom design a unit that fits your needs perfectly.

Semler Industries brings over 100 years of meeting customers' demands and 50+ years serving the petroleum and chemical markets together to meet the fuel polishing needs of our customers. We provide custom systems for mission critical applications, generator service companies, and anyone in the marine, transportation, mining and agricultural industries who rely on diesel fuel. From portable 2-wheel carts to permanent/automated units, everything we do is focused on maintaining the quality of the diesel, and making it easy for you to handle.



Semler Industries Inc.

3800 North Carnation Street
Franklin Park, IL 60131 USA
Phone: (847) 671-5650
Fax: (847) 671-7686
semler@semlerindustries.com

FuelPolishingSolutions.com
SemlerIndustries.com