



## Why?

Water, dirt and sediments can accumulate in stored diesel fuel and threaten the quality of the fuel and the performance of the engine. Semler's PetroPolisher™ systems are engineered to remove these threats quickly and efficiently. The FlexMax 150 is designed for commercial operators' use on large capacity storage tanks that require high-capacity filtration and water separation, and can return fuel to specifications that meet regulatory requirements. Operators will find this unit ideal for addressing variable fuel filtration concerns. Designed with staged solid's removal, coalescing, and fine filtration abilities, the FlexMax 150 delivers professional results for the most demanding conditions.

### Semler Industries Inc.

3800 North Carnation Street  
Franklin Park, IL 60131 USA

Phone: (847) 671-5650

Fax: (847) 671-7686

semler@semlerindustries.com

[FuelPolishingSolutions.com](http://FuelPolishingSolutions.com)  
[SemlerIndustries.com](http://SemlerIndustries.com)

# PetroPolisher™ FlexMax 150



*This unit is  
ideal for tanks  
8,000 to  
20,000 gallon*

**Maximum Flexibility**  
**Maximum Purity**  
**Maximum Durability**

### STANDARD PACKAGE

- Professional grade construction
- 150 gpm self-priming pump
- Variable-speed flow control
- High-capacity filters for water and solids removal
- Duplex pre-filter housing for continuous operation
- Robust suction and discharge hoses
- Pressure gauges for vessel monitoring
- Isolation valves for desired filtering path
- Fuel monitoring with inline sight flow indicator
- Rate-of-flow meter



### OPTIONS

- Flow rates 23 to 200+ gpm
- Air or hydraulic motors, gas or diesel driven engines, or other power options
- Coarse or fine filter efficiency
- Color choice
- Permanently mounted, automated, and trailer-mounted
- User interface with real-time operating parameters and alarm condition outputs

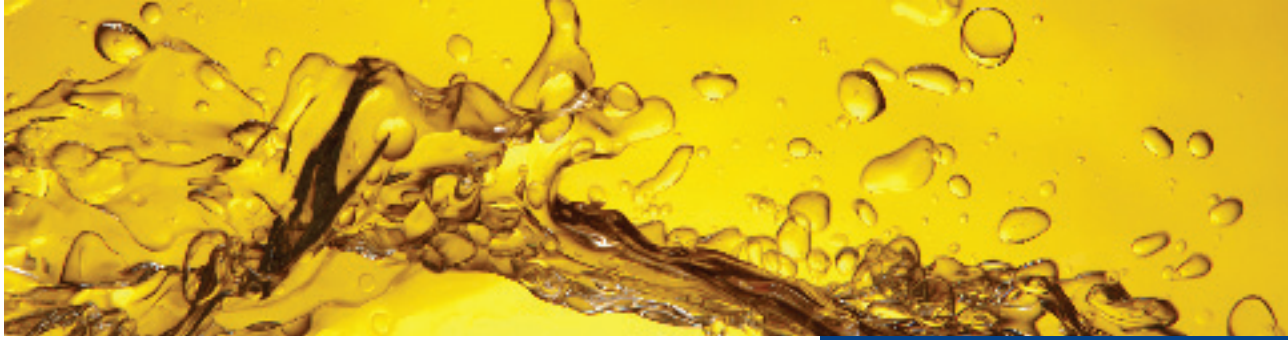

### Solids Removal

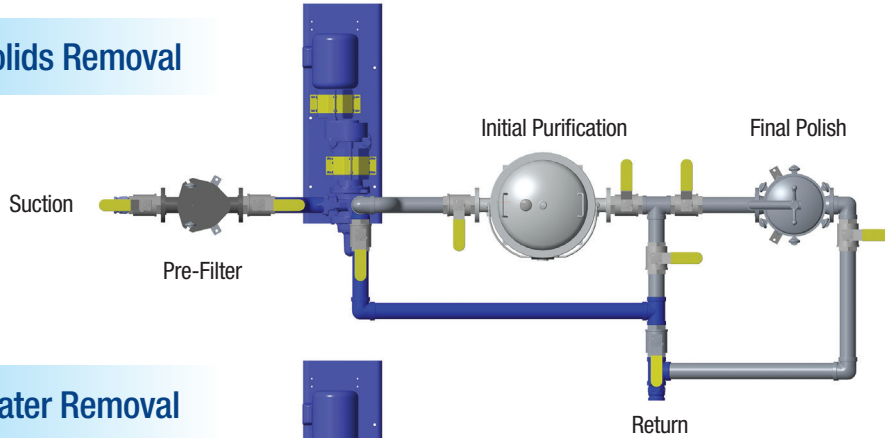

### Water Removal

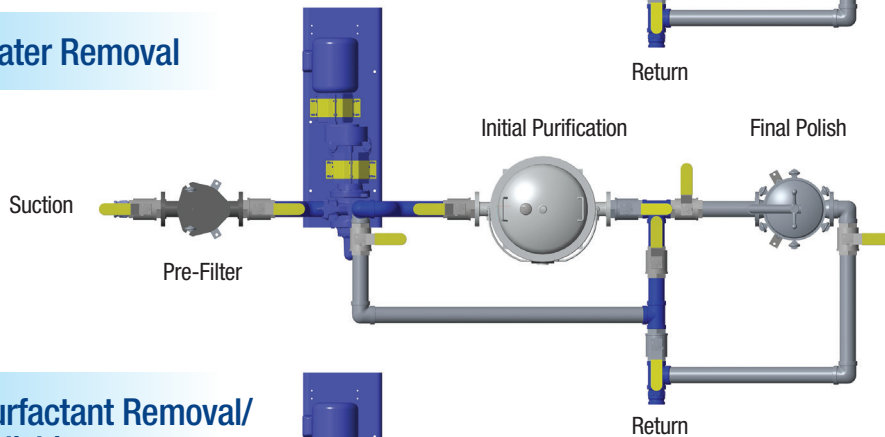

### Surfactant Removal/ Polishing

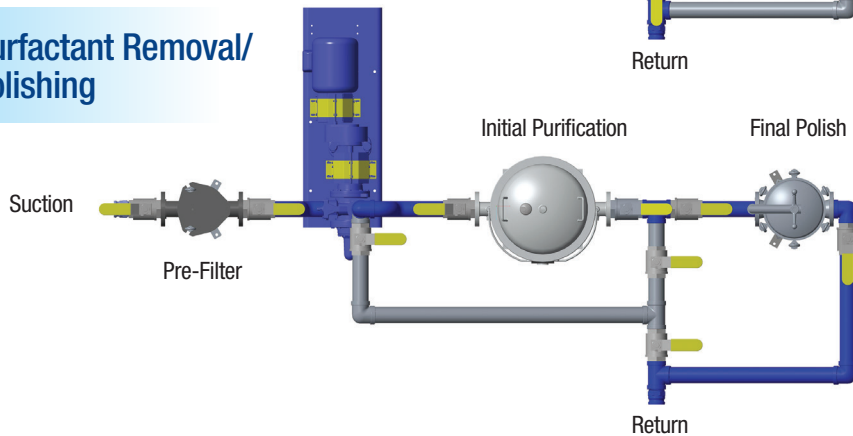

By incorporating a bag-filter housing, a large element housing and a specific coalescer-separator housing in series, we have allowed for the operator to mix and match a wide variety of media types to address any and almost all concerns with diesel contamination. Not sure which media to use? Don't worry- contact a Semler fuel expert for some guidance and suggestions.

### OTHER OFFERINGS BY SEMLER



23gpm Single filter  
PetroPolishers



35gpm Single filter  
PetroPolishers



DEF Transfer Carts  
and Systems



200gpm Oil and Engine  
Fluid Transfer Skids



Absorbent Media  
& Spill Kits

Do you have a unique situation? Many of our customers do. Just let us know and our engineers can custom design a unit that fits your needs perfectly.

Semler Industries brings over 100 years of meeting customers' demands and 50+ years serving the petroleum and chemical markets together to meet the fuel polishing needs of our customers. We provide custom systems for mission critical applications, generator service companies, and anyone in the marine, transportation, mining and agricultural industries who rely on diesel fuel. From portable 2-wheel carts to permanent/automated units, everything we do is focused on maintaining the quality of the diesel, and making it easy for you to handle.



### Semler Industries Inc.

3800 North Carnation Street  
Franklin Park, IL 60131 USA  
Phone: (847) 671-5650  
Fax: (847) 671-7686  
semler@semlerindustries.com

[FuelPolishingSolutions.com](http://FuelPolishingSolutions.com)  
[SemlerIndustries.com](http://SemlerIndustries.com)